

شركة مجموعة نبراس المعادن المحدودة
NIPRAS METAL GROUP COMPANY Ltd.

PVC CHAMFER DATASHEET





شركة نبراس المعدن للصناعة NIPRAS METAL INDUSTRY Co.

Introduction

NIPRAS METAL GROUP (NMG)

- Established in the year 2010 with high quality Manufacturing & Trading expertise with 3 companies under the umbrella -

1. NIPRAS METAL INDUSTRY COMPANY (NMIC)
2. NIPRAS METAL TRADING COMPANY (NMTC)
3. NIPRAS METAL CONTRACTING Est. (NMCE)

We are a Saudi based company with our team in major cities across the kingdom with our headquarters in RIYADH providing the best & professional solutions in construction & architectural industry. Intuitive creativity, precise technical assistance and reputed interest in our client marked us as one of the leading Industries throughout the KINGDOM and other GCC countries.

We have a plan to build the successful businesses for today's economy. We aim at manufacturing our products to not only have a beautiful appearance, but also that the customers perceive something of great intrinsic value when they touch it. We constantly strive to create future products that will stimulate the customer's senses to bring about joy and excitement each time the product is used.

Our success will be validated when the end users use the product and "their heart leaps for joy" and "they are deeply moved". We will create a future without limits through valued manufacturing. We will be responsible for planning, development, and manufacturing and be considered as the only manufacturer of its kind. We have earned great respect as a manufacturer and trader by serving the best to our valued customers.

1. Accountability

We accept responsibility for our work products and services. Upholding the highest standards evaluating for measuring our results against stated performance for our work with relevance, credibility and timelessness.

2. Teamwork

Our success depends on working together and fostering an inclusive and mutually supportive environment.

Our work-friendly for environment encourages collaboration, innovation, flexibility and figure the integration of resources.



Our Strength Factors

3. Communication

We clarify expectations up front and communicate openly, honestly and accurately. We look for ways to improve our ways and for our work products by seeking giving and use both praise and constructive feedback.

4. Respect

We promote diversity and equal opportunity throughout other organizations. We value and respect the views of our clients.



PVC CHAMFER

NMTE PVC chamfers are manufactured from tough durable PVC which has been designed to withstand expected site conditions enabling several re-uses. PVC Chamfers provide smooth and professional finish for all right-angle materials intersections. E.g. corners, walls, column and beams etc. PVC Chamfer is having nail hole slots to fix easily to formwork.



Available material option:

- Polyvinylchloride (PVC)
- Polyethylene (PE) - ONLY the items DFVxxPE
- Free of CFC, HFC
- Free of PVC – ONLY the items DFVxxPE
- Without substances of very high concern according to the candidate list of ECHA (REACH Regulation)

Uses:

- To form chamfered edges to columns.
- To form chamfered edges to precast concrete panels.
- It doesn't adhere to concrete and therefore provide clean arises when removed.

ORDERING INFORMATION, WITHOUT NAIL STRIP

Reference Code	Size (mm)			Length (meter)	m/ Bundle
	(a)	(b)	(c)		
N-WPC006	06	06	09	2.5	100
N-WPC010	10	10	15	2.5	100
N-WPC015	15	15	21	2.5	100
N-WPC020	20	20	28	2.5	100
N-WPC025	25	25	35	2.5	100
N-WPC030	30	30	41	2.5	100

**Full, no nailing hole*

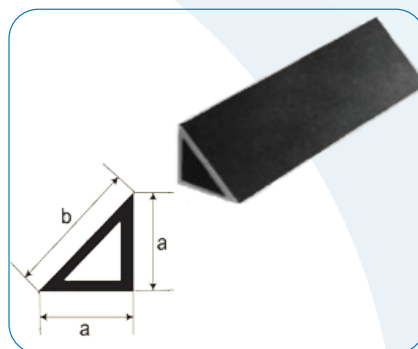

INFORMATION:

The information given is the best that NIPRAS researched and prepared at this time.
The instruction sheets are recommendations. Correct use is the responsibility of the user.
NIPRAS does not guarantee the accuracy and completeness of the information.
All rights for changes, mistakes, sentence and printing errors reserved.
Reprint only with written permission of NIPRAS.

ORDERING INFORMATION, WITH NAIL STRIP HOLLOW

Reference Code	Size (mm)			Length (meter)	m/ Bundle
	(a)	(b)	(c)		
N-WPCFH010	10	15	24	2.5	100
N-WPCFH015	15	21	31	2.5	100
N-WPCFH020	20	28	36	2.5	100
N-WPCFH025	25	35	45	2.5	50
N-WPCFH030	30	41	53	2.5	50

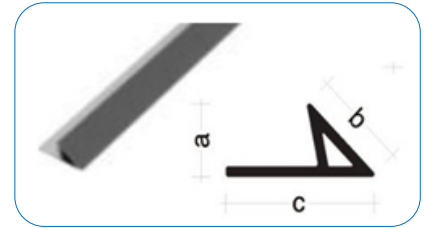

ORDERING INFORMATION, WITH NAIL STRIP FULL

Reference Code	Size (mm)			Length (meter)	m/ Bundle
	(a)	(b)	(c)		
N-WPCFV007	7	10	20	2.5	100
N-WPCFV010	10	15	25	2.5	100
N-WPCFV015	15	21	30	2.5	100

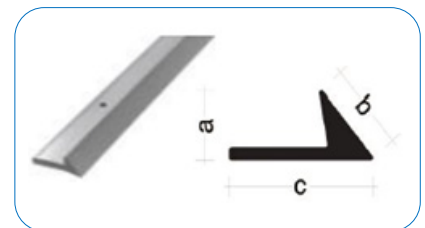

ORDERING INFORMATION, WITH NAIL STRIP FULL, HDPE

Reference Code	Size (mm)			Length (meter)	m/ Bundle
	(a)	(b)	(c)		
N-WPCFV10PE	10	15	25	2.5	200
N-WPCFV15PE	15	21	30	2.5	120

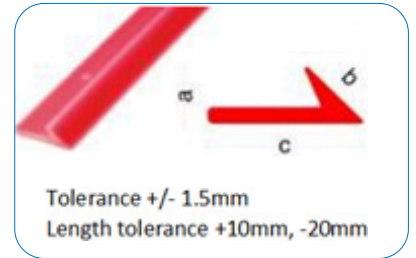

- Especially suitable for use with compressed air gun
- Even at low temperatures high impact strength
- As a result of the material polyethylene (PE) flexible and bendable, therefore also suitable for the use at a radius.

INFORMATION:

The information given is the best that NIPRAS researched and prepared at this time.
The instruction sheets are recommendations. Correct use is the responsibility of the user.
NIPRAS does not guarantee the accuracy and completeness of the information.
All rights for changes, mistakes, sentence and printing errors reserved.
Reprint only with written permission of NIPRAS.

INSTALLATION

NIPRAS Chamfers can be easily fixed by direct nailing to shuttering.

 Tel : +966 570998080

 info@nipras.sa

 www.nipras.sa

NMG NIPRAS
METAL GROUP

شركة مجموعة نبراس المعادن المحدودة
NIPRAS METAL GROUP COMPANY Ltd.



 6353 Al Musafat area P.O Box:236300
Al Riyadh 14543